

Model 660SJ

TELESCOPIC BOOM LIFTS



MORE ECONOMIC

- Lower hydrocarbon, carbon monoxide, particulate and NOx emissions with Stage IIIB-compliant engine.

MORE PRODUCTIVE

- Equipped with hydrostatic drive for easy, precise, infinitely-variable-speed manoeuvrability.

MORE ACCESS

- Conquer rough terrain with standard oscillating axle and four-wheel drive, delivering optimised grip and stability.

SMART DESIGN

- Fewer buttons and switches used to position the platform and less time spent learning to use the platform controls.



Standard Features

- 0.91 m x 1.83 m low mount platform
- Side entry with drop bar mid rail
- Multiple function operation
- Full proportional drive joystick control with integral thumb steer switch
- Full proportional main boom and swing joystick control
- Multiple speed control for telescope and platform rotate
- Selectable creep speed on drive / lift and swing functions
- 1.83 m articulating jib
- 180 degree powered platform rotator
- Platform console machine status light panel ¹
- Load sensing system
- AC cable to platform
- Engine distress warning/shut down system ²
- Gull-wing hoods
- 3 degree tilt alarm and indicator light
- Lifting/tie down lugs
- Hour meter
- Ground control selector switch with key lock
- Platform tool tray
- 12V DC auxiliary power
- Four wheel drive
- Oscillating front axle
- Cast Aluminum Control Box
- Horn
- Hydrostatic drive transmission
- Swing-out engine tray
- Control ADE® Advanced Design Electronics System
- JLG Skyguard active system

¹ Provides indicator lights at platform control console for system distress, low fuel, tilt light, and foot switch status.

² Low oil pressure and high coolant temperature alarms with shut-down enabled/disabled by analyser.

Standard Specifications

Power Source	
• Diesel Engine Deutz D2011L04	36.4 kW
• Fuel Tank Capacity	151 L
Hydraulic System	
• Hydraulic System	151 L
• Auxiliary Power	12V DC
Tyres	
• Tyres	39 x 15-22.5 Foam Filled

³ Available when integrated with the SkyPower® package.

⁴ Consists of six 40-watt lights, four turntable mounted lights and two platform mounted lights.

⁵ Available only with two wheel drive on models 600S and 660SJ.

⁶ Includes all-motion alarm and flashing amber beacon.

⁷ Includes platform mounted work lights and head & tail lights.

⁸ Includes console cover, boom wipers and cylinder bellows.

Accessories & Options

- 0.91 m x 2.44 m slide bar side entry platform
- 0.91 m x 2.44 m Self closing inward swing gate
- 13 mm air line to platform
- Four Wheel Steer/Two Wheel Steer
- 15 x 19.5 foam filled non marking tyres
- On-board 4,000 W generator
- SkyPower® package 7,500 watt on-board generator
- SkyWelder® package 250 amp welder in the platform ³
- Nite-Bright® package ⁴
- Tow Package ⁵
- All motion alarm
- Alarm package ⁶
- Light package ⁷
- Head and tail lights
- Flashing amber beacon
- Euro Plug & Socket
- Hostile environment kit ⁸
- Hydraulic oil cooler
- Catalytic Exhaust Purifier (Deutz)
- Soft Touch 0.91 m x 1.83 m Platform Proximity System
- Soft Touch 0.91 m x 2.44 m Platform Proximity System
- Soft Touch 0.91 m x 2.44 m fall arrest system
- Skyguard beacon (ILOS)
- Arctic package
- Generator hourmeter
- Synthetic Biodegradable Hydraulic Oil
- Platform worklights
- Special paint colour
- Fixed Axle
- Two Wheel Drive
- Tow Bar

Model 660SJ

TELESCOPIC BOOM LIFTS

Performance

- Working Height 22.31 m
- Working Outreach 17.95 m
- Swing (Continuous) 360°
- Platform Capacity – Unrestricted 230 kg
- Platform Rotator (Hydraulic) 180°
- Jib – Overall Length 1.83 m
- Jib – Range of articulation 130° (+70°-60°)
 - A. Platform Size 0.91 m x 1.83 m
 - B. Overall Width 2.49 m
 - C. Tailswing (working condition) 1.14 m
 - D. Stowed Height 2.57 m
 - E. Overall Length 10.88 m
 - F. Wheelbase 2.48 m
 - G. Ground Clearance 0.30 m
- Stowed Length 10.21 m
- Machine weight ^{1/2} 12,720 kg
- Maximum Ground Bearing Pressure ² 5.27 kg/cm²
- Maximum Tyre Load 6,455 kg
- Drive Speed 4WD 6.8 km/h
- Gradeability 4WD 45%
- Axle Oscillation (optional) 0.20 m
- Turning Radius – Inside 4WS 1.40 m
- Turning Radius – Outside 4WS 2.89 m

¹ Certain options or country standards may increase weight and/or dimensions.

² With Standard tires



Reach Diagram

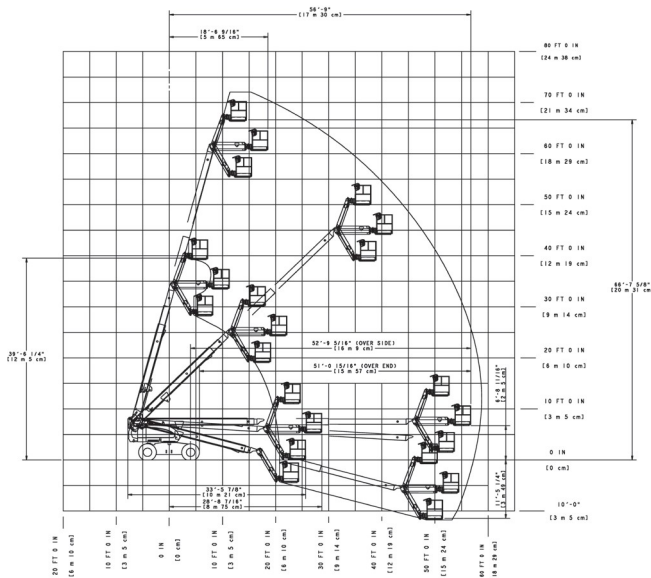

Dimensions

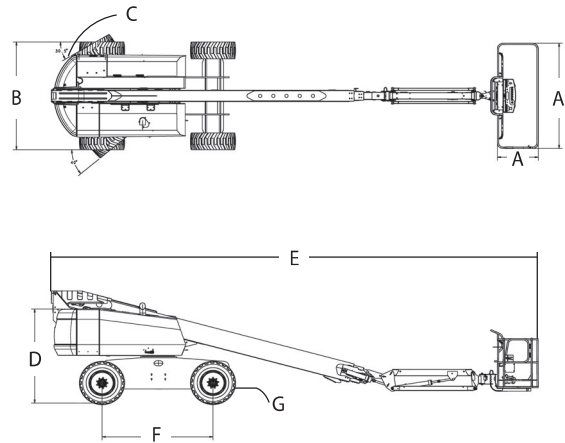

IMPORTANT

JLG is continually researching and developing products and reserves the right to make modifications without prior notice. All data in this document is indicative. Certain options or country standards will increase weight. Specifications may change to meet country standards or with the addition of optional equipment.

Due to continuous product improvements, JLG Industries reserves the right to make specification and/or equipment changes without prior notification.



JLG EMEA BV

Polaris Avenue 63
2132 JH Hoofddorp
The Netherlands
Tel: +31 (0)23 565 5665
Fax: +31 (0)23 557 3750
www.jlg.com

An Oshkosh Corporation Company